

Perspective View

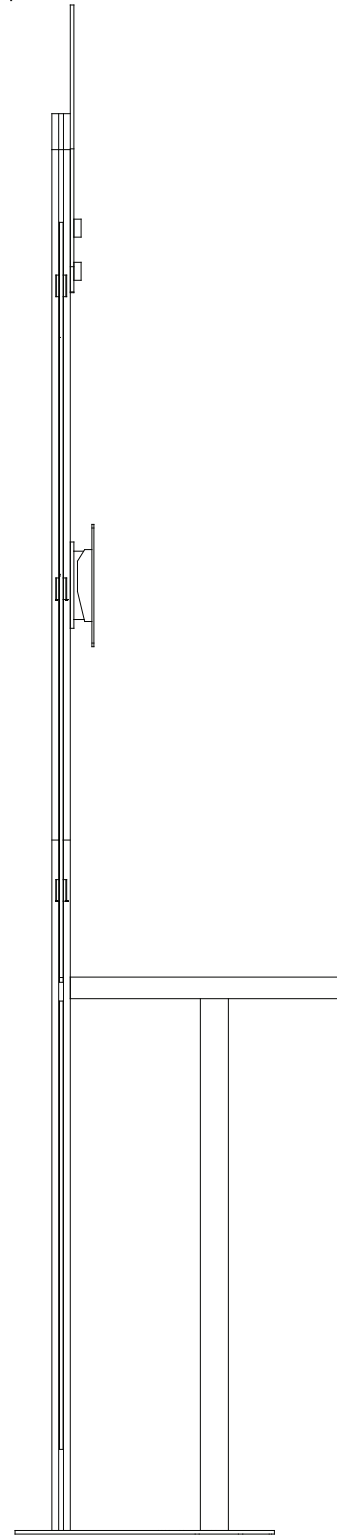

Side View

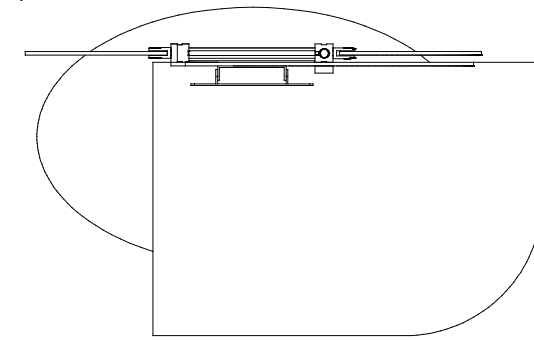

Top View

General Setup Instructions

- Read entire setup instruction manual prior to unpacking parts and pieces.
- The setup instructions are created specifically for this configuration.
- Setup instructions are laid out sequentially in steps, including exploded views with detailed explanation for assembly.

Cleaning & Packing

- For Cleaning Metal, Plex, & Laminate Parts: Use a **MILD NON-ABRASIVE** cleanser and soft cloth/paper towel to clean all surfaces.
- Keep exhibit components away from heat and prolonged sun exposure.
Heat and UV exposure will warp and fade components.
- Retain all provided Packing Materials. All provided packing materials are for ease of repacking & component protection.

Disassembly

- For loss prevention, tighten all set screws and locks during disassembly.

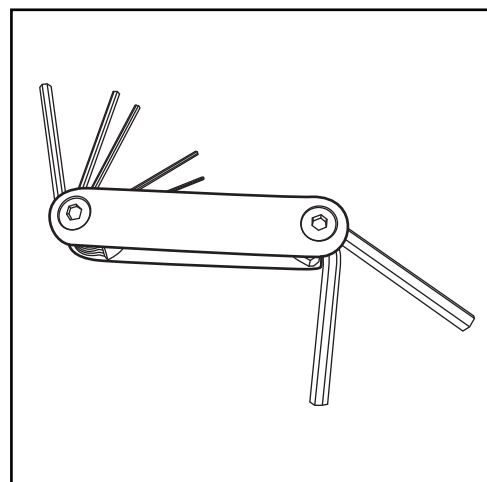

Hex Tool - Essential for Assembly

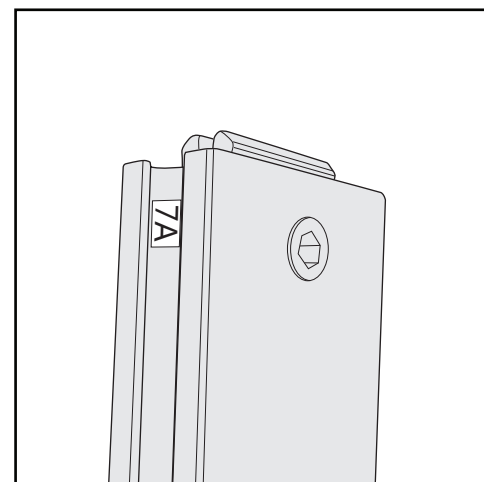

Part Identification - Numbering

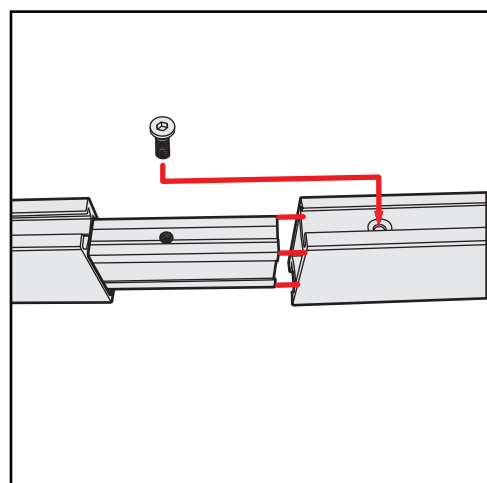

Spline Connection

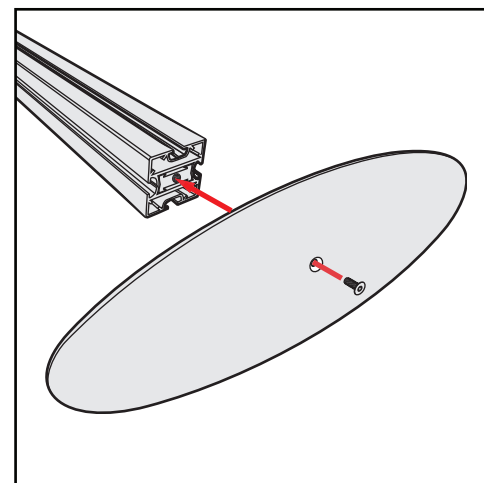

Base Plate & Extrusion Connection

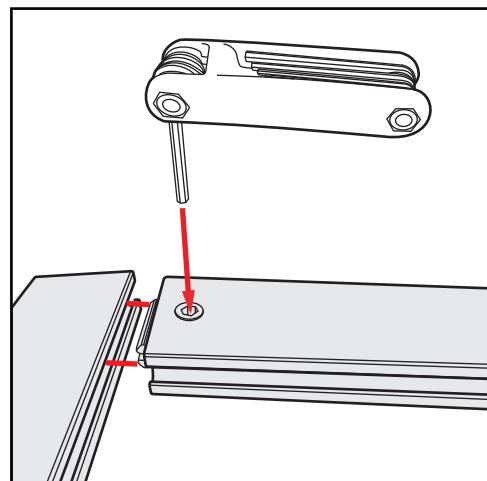

Extrusion & Lock Connection

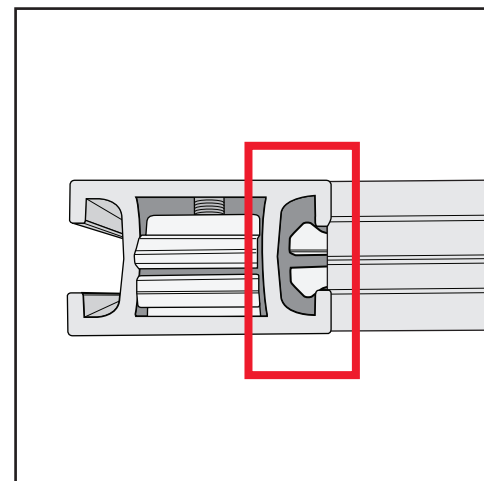

Engaged Lock



WARNING



DO NOT USE POWER TOOLS



LADDERS OR LIFTS
MAY BE REQUIRED



ALL CONNECTIONS MUST
BE TIGHTLY SECURED

Item	Qty.	Description
1	1	Base Plate
2	1	48" S40 Vertical Extrusion w/ Stopper
3	1	48" S40 Vertical Extrusion
4	1	2.5" Angle-Cut Extrusion
5	1	48" S40 Vertical Extrusion
6	1	44" S40 Vertical Extrusion
7	1	8.747" Z45 Horizontal Extrusion
8	2	8.747" Z45 Horizontal Extrusion
9	1	37.75" RS500 Vertical Extrusion
10	1	Flange Plate
--	1	Sign
--	2	Wing
--	3	Infill

Steps:

- 1) Attach [4] to [3]. See **Extrusion Attachment** detail.
- 2) Attach [2] [5] and [9] to base plate [1], using bolts.
- 3) Attach [3] to [2] and [6] to [5].
See **Extrusion Connector** detail.
- 4) Slide lower infill between assemblies to rest on stopper in vertical [2].
- 5) Secure infill with horizontal [7].
- 6) Slide center infill between assemblies to rest on attached horizontal [7].
- 7) Secure infill with horizontal [8].
- 8) Slide top infill between assemblies to rest on attached horizontal [8].
- 9) Secure infill with horizontal [8]
- 10) Attach sign to vertical [6], using screw caps.
See **Sign Attachment** detail.
- 11) Place wings into clamps. Tighten knobs to secure.

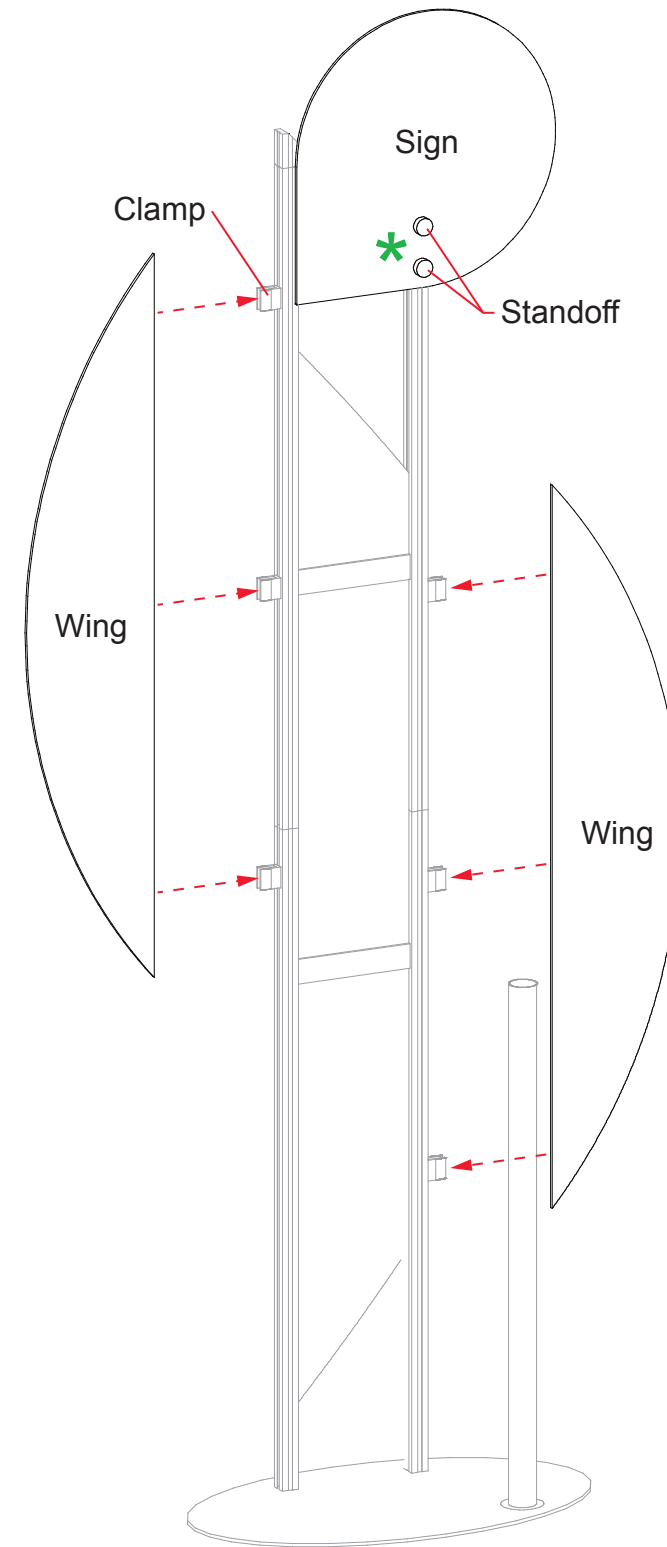
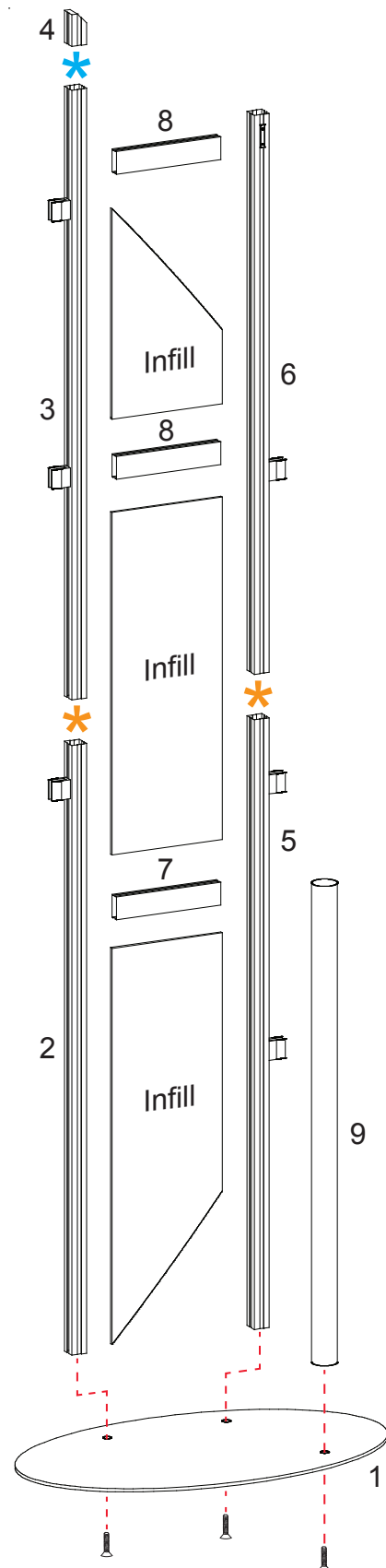
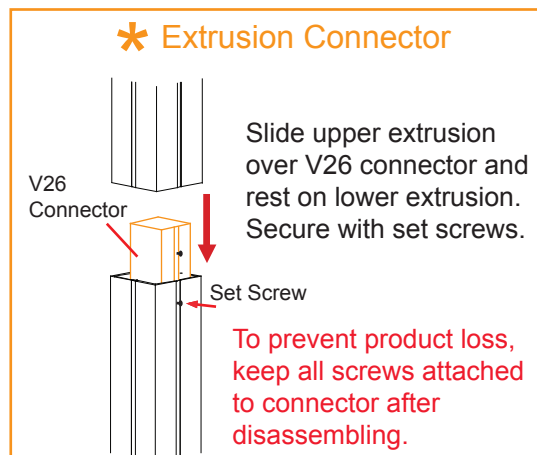

Keep V26 connectors attached to extrusions [2] and [5].

Keep clamps attached to [2] [3] [5] and [6].

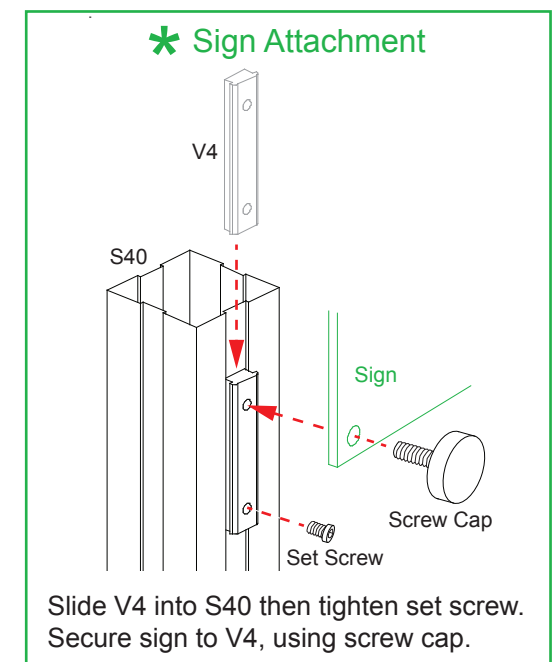
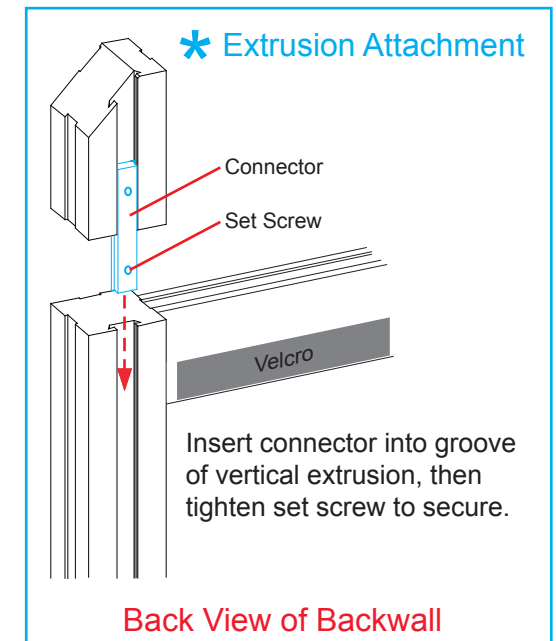

Steps:

- 1) Attach counter to [9] and [7].
See [Counter Attachment](#) detail.
- 2) Attach monitor mount to [3] and [6].
See [Monitor Mount Attachment](#) detail.
- 3) Route monitor cord through conduit. See [PR63 Attachment](#) detail.

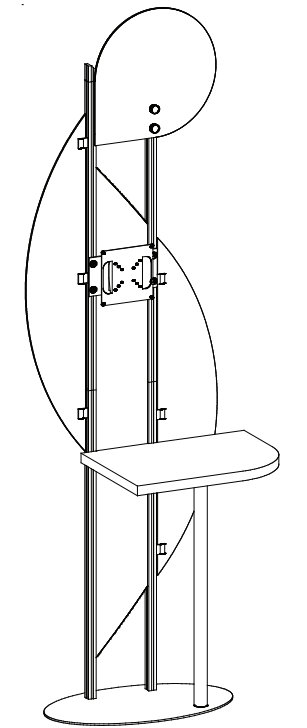
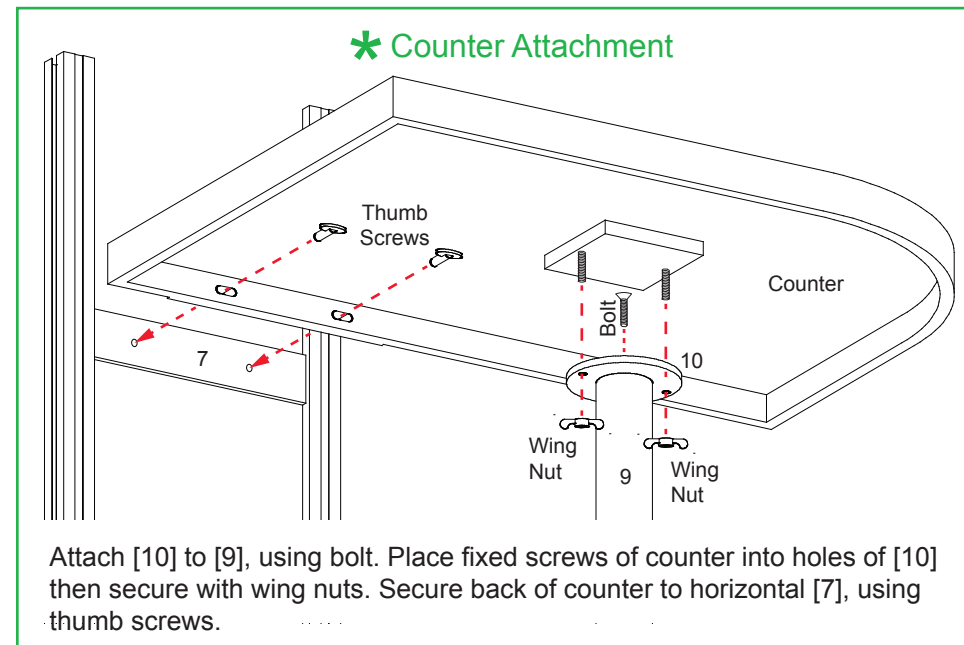
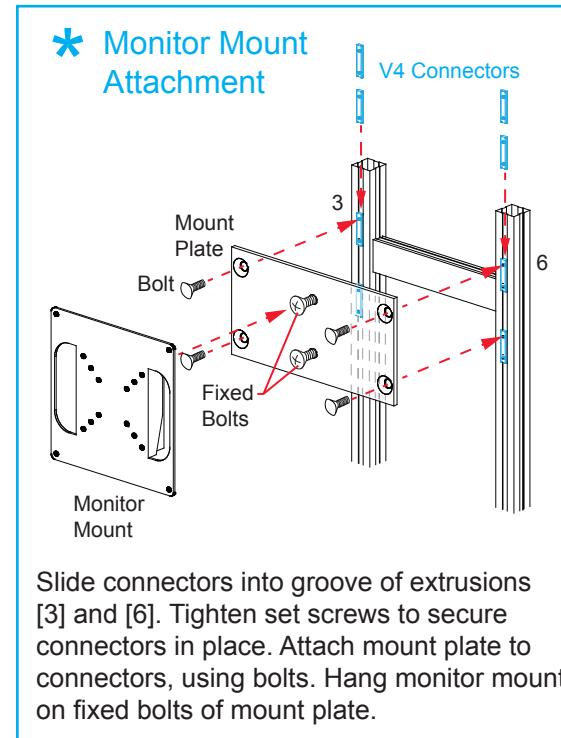
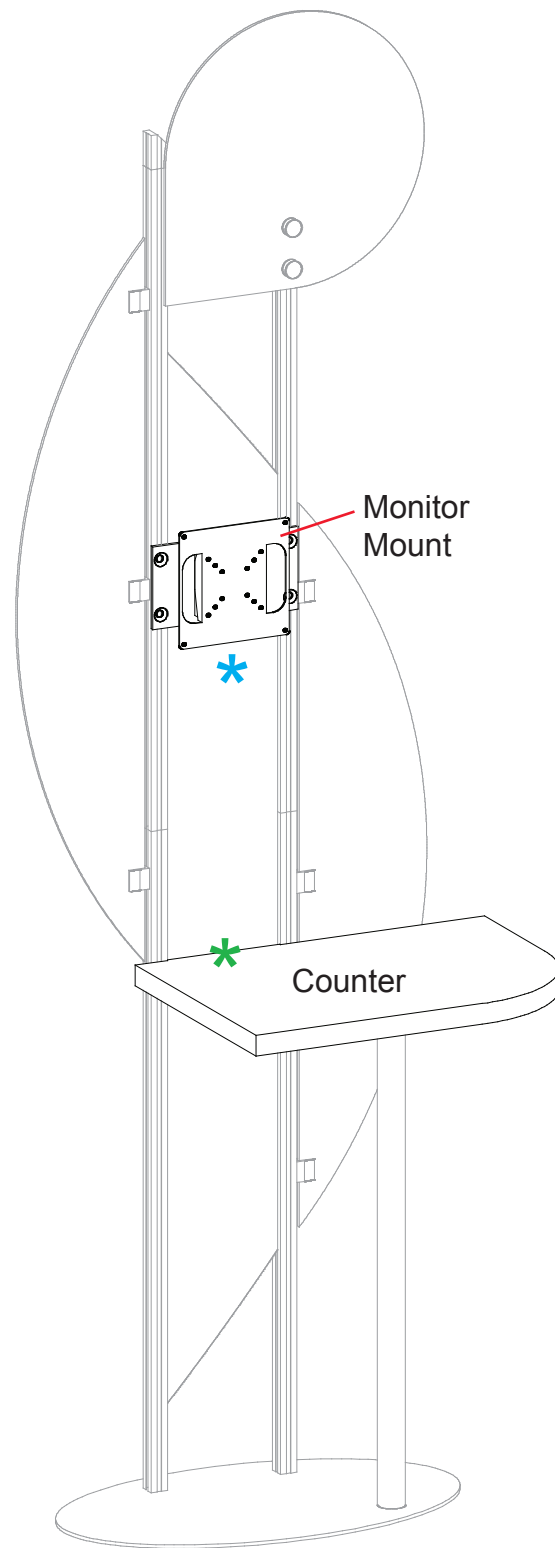
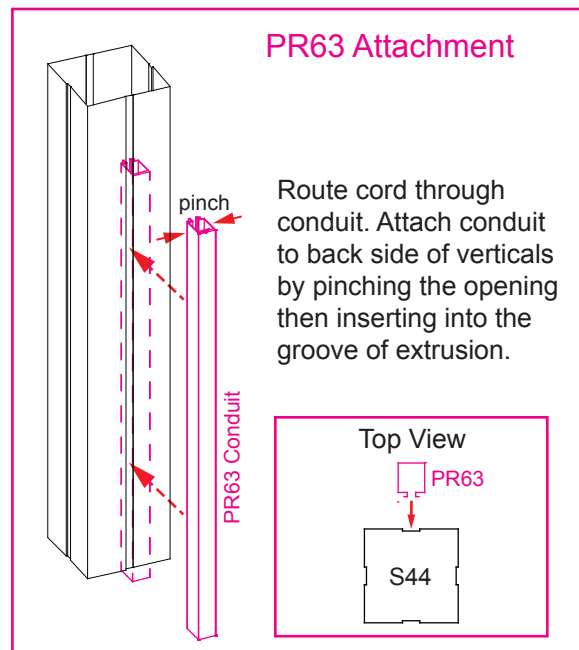

Completed Assembly

Attach [10] to fixed screws on counter, using wing nuts, when packing.